

Cleaning GE Profile dishwashers

These are very good dishwashers and tend to work for many years without needing much attention, but ours (model no. PDW8280NOOSS) recently began leaving white spots and film on glassware and also leaving spots on stainless steel tableware. We also noticed that there was a layer of white soap scum left on the grey screen in the bottom of the tub.

Cleaning the circulation and filtering system

Dishwashers are made to either grind up and flush away loose food left on the dishes, or not. The GE Profile ones don't grind, because it would make them noisier. So, the bits of food left on the dishes have to be filtered out of the water somewhere to keep it from being pumped over the dishes several times during cleaning and rinse cycles. Eventually, residue accumulates on the filters and in the openings in the rotating sprayers, and the water doesn't circulate as well. What does circulate is contaminated, the drain system doesn't work properly, and there may be odors from the residue.

The remedy is to clean the filter and the circulation system. Below is the link to a very well made YouTube.com video that steps you through that process. I was able to do ours in about 90 minutes or so with no real mess to clean up, and there are no replacement parts to buy. And it fixed the spotting and scum problems.

<https://www.youtube.com/watch?v=3BtVLcT9E5A>

Let the video guide you, and just lay out the parts on the kitchen floor in a long line in the order you remove them. That will make it easy to put everything back together in the right order.

I couldn't turn the "hub venturi assembly", the **part circled here**, loose from the bottom of the tub. Don't force it because it's plastic and attached to the plastic pump, and listed as *no longer in stock* on parts supply websites. Take the hint.

One additional thing I would add to the job is to brush out the water-filled sump under the filter cartridge, where a lot of crud accumulates, then run part of the flush and clean cycle without the filter in place to eliminate that residue.

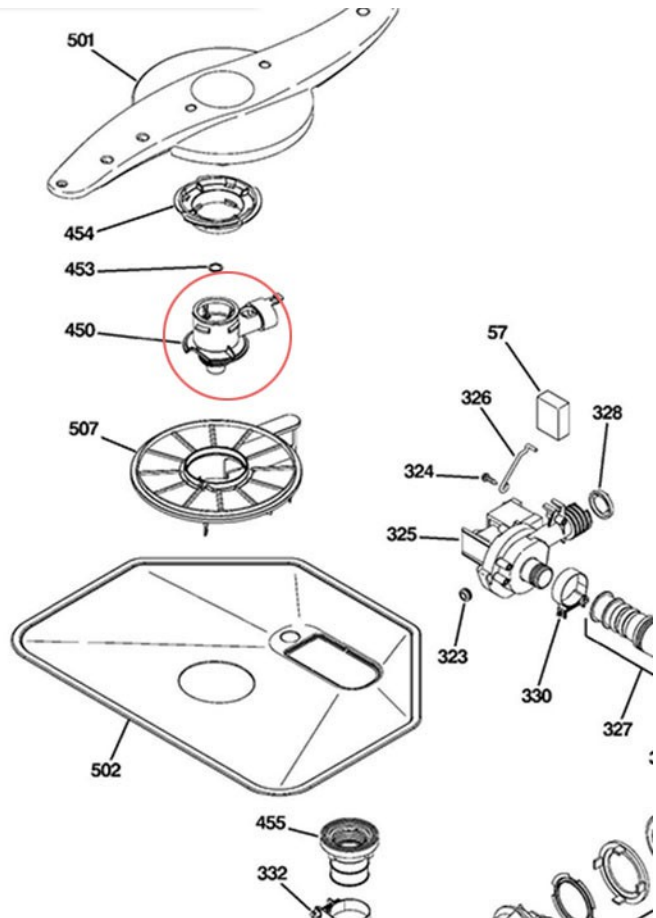

Ongoing maintenance

After going to all the work to clean the filters, etc., it would seem like a good idea to rinse dishes to some degree before putting them in the dishwasher, to at least slow down future problems from developing. Putting a food through the thing is how it got clogged in the first place. A side benefit is that you can set the clean cycle to go right to NORMAL WASH and eliminate any pre-rinsing, saving some water. Try it.

Most of the maintenance forums and videos recommend that you occasionally (1) place a clean bowl with a couple cups of cheap vinegar toward the center of the bottom rack, then run the dishwasher on the normal cycle without detergent. The dispersal of vinegar throughout the cycle should leave your dishwasher cleaned of soap scum and food deposits. And in a separate operation (2) sprinkle a cup of baking soda in the bottom of your dishwasher. Let it sit overnight. In the morning, run an empty cycle, and the interior will have been sanitized and deodorized.

Researched and edited by Chuck Probst
ceprobst@comcast.net (540)967-0416